



Flameproof & Weatherproof LED Light Fixture

Moonstar

● Technical Data : LLF 61...SERIES

ENCLOSURE :

Ex-d, GAS Gr. IIA, IIB, IIC AS PER IS/IEC 60079-1:2007 & IS/IEC 60079-0:2004

PROTECTION :

IP-66 AS PER IS/IEC 60529:2001

AREA CLASSIFICATION :

ZONE-1, 2, 21 & 22

CERTIFICATION :

CIMFR/TC/P/610

MATERIAL OF CONSTRUCTION :

DIE CAST ALUMINUM ALLOY

RATED VOLTAGE :

AS PER TABLE

RATING & TEMP. CLASSIFICATION :

AS PER TABLE

TRANSPARENT PART :

HEAT, RESISTANT & TOUGHENED CLEAR DOME GLASS

FINISH :

DARK ADMIRALTY GREY EPOXY POWDER COATED SHADE 632 AS PER IS:5

HARDWARE :

STAINLESS STEEL

EARTHING :

1 No. INSIDE & 2 Nos. OUTSIDE

CABLE ENTRY :

M20 x 2 Nos.

OPTIONAL ACCESSORIES AT EXTRA COST :

- 1) MOUNTING BRACKET
- 2) DOUBLE COMPRESSION CABLE GLAND/STOPPER (BNP/SS)
- 3) PAINT SHADE AS PER CUSTOMER REQUIREMENT.

REPLACES :

- 1) 20W LED : 80W HPMV, 2x20W CFL LAMPS.
- 2) 30W LED : 160W MLL, 2x26W PL, 2x23W CFL LAMPS.
- 3) 45W LED : 125W HPMV, 70W MH/HPSV LAMPS.
- 4) 60W LED : 250W HPMV, 150W MH/HPSV LAMPS.
- 5) 90W LED : 400W HPMV & 250W MH/HPSV LAMPS.
- 6) 120W LED : 400W MH/HPSV LAMPS.

SPECIAL FEATURES :

- A) LIGHT WEIGHT
- B) COMPACT DESIGN
- C) EXCELLENT HEAT DISSIPATION TECHNOLOGY
- D) SUPERIOR FINISH WITH EPOXY POWER COATED
- E) EAST INSTALLATION
- F) DIE CAST ENCLOSURE

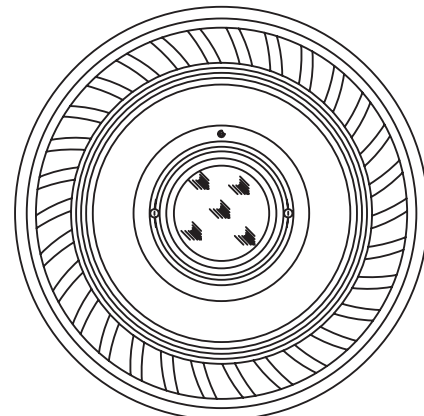
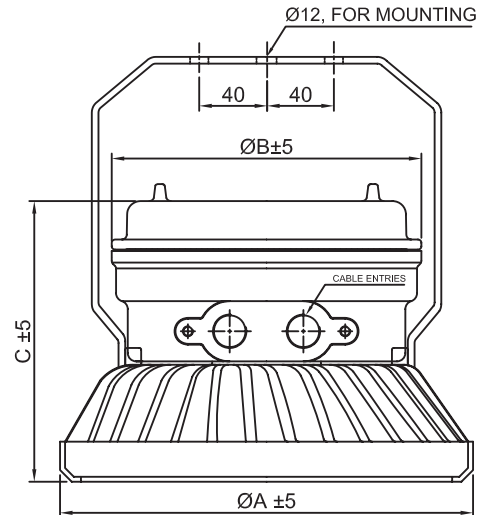

SR. No.	TYPE No.	RATING & TEMP.	Dimension		
			ØA ±5	ØB ±5	C ±5
1	LLF 61020	20W LED LAMP 250V AC 50Hz & T6	Ø235	Ø140	180
2	LLF 61030	30W LED LAMP 250V AC 50Hz & T6	Ø235	Ø140	180
3	LLF 61045	45W LED LAMP 250V AC 50Hz & T6	Ø235	Ø140	180
4	LLF 61060	60W LED LAMP 250V AC 50Hz & T6	Ø295	Ø185	180
5	LLF 61090	90W LED LAMP 250V AC 50Hz & T6	Ø295	Ø185	230
6	LLF 61120	120W LED LAMP 250V AC 50Hz & T6	Ø295	Ø185	230